

Burners



**Oxy-fuel burners
series HT “high turbulence”**

HT (E3710 rev. 01 - 31/10/2012)

GENERAL WARNINGS:



■ All installation, maintenance, ignition and setting must be performed by qualified staff, respecting the norms present at the time and place of the installation.

■ To avoid damage to people and things, it is essential to observe all the points indicated in this handbook. The reported indications do not exonerate the Client/User from observing general or specific laws concerning accidents and environmental safeguarding.

■ The operator must wear proper DPI clothing (shoes, helmets...) and respect the general safety, prevention and precaution norms.

■ To avoid the risks of burns or high voltage electrocution, the operator must avoid all contact with the burner and its control devices during the ignition phase and while it is running at high temperatures.

■ All ordinary and extraordinary maintenance must be performed when the system is stopped.

■ To assure correct and safe use of the combustion plant, it is of extreme importance that the contents of this document be brought to the attention of and be meticulously observed by all personnel in charge of controlling and working the devices.

■ The functioning of a combustion plant can be dangerous and cause injuries to persons or damage to equipment. Every burner must be provided with certified combustion safety and supervision devices.

■ The burner must be installed correctly to prevent any type of accidental/undesired heat transmission from the flame to the operator or the equipment.

■ The performances indicated in this technical document regarding the range of products are a result of experimental tests carried out at ESA-PYRONICS. The tests have been performed using ignition systems, flame detectors and supervisors developed by ESA-PYRONICS. The respect of the above mentioned functioning conditions cannot be guaranteed if equipment, which is not present in the ESA-PYRONICS catalogue, is used.

DISPOSAL:



To dispose of the product, abide by the local legislations regarding it.

GENERAL NOTES:



■ In accordance to the internal policy of constant quality improvement, ESA-PYRONICS reserves the right to modify the technical characteristics of the present document at any time and without warning.

■ It is possible to download technical sheets which have been updated to the latest revision from the **www.esapyronics.com** website.

■ The HT products have been designed, manufactured and tested according to the most correct construction practices and following the applicable requirements described in **UNI EN 746-2-2010** 'Industrial heating process equipment - Part 2: Safety requirements for combustion and for the handling and processing of fuels'. We emphasize that the burners described in this data sheet **are provided as independent units and are excluded from the scope of the Machine Directive 2006/42/EC** not having any mobile items that are not exclusively manual.

■ Certified in conformity with the **UNI EN ISO 9001** Norm by DNV GL.

CERTIFICATIONS:



The products conform to the requests for the Euroasia market (Russia, Belarus and Kazakhstan).

CONTACTS / SERVICE:



Headquarters:

Esa S.p.A.
Via Enrico Fermi 40
24035 Curno (BG) - Italy
Tel +39.035.6227411
Fax +39.035.6227499
esa@esacombustion.it

International Sales:

Pyronics International s.a.
Zoning Industriel, 4ème rue
B-6040 Jumet - Belgium
Tel +32.71.256970
Fax +32.71.256979
marketing@pyronics.be

www.esapyronics.com

The HT series oxy-fuel burners have been conceived for an extremely flat and high flame generation thanks to the intense mixture of pure oxygen (technical purity degree 90% - 99,9%) and gas at the burner mouth.

APPLICATIONS

- Melting tank furnaces for ceramic frits.
- Melting furnaces for metals.
- Melting furnaces for glass.
- Ladle heating stations for steel mills.



F3710HTI03

CHARACTERISTICS

GENERAL:

- Capacity: from 10 to 5000kW
- Functioning with various types of fuel gas:
CH4/LPG/Propane/etc.
- Maximum furnace temperature: 1750°C if supplied
with refractory block
- O2 burner inlet pressure: min 100 mbar
- Inlet fluid temperature: room temperature
- Flow ratio: 1:5
- Low CO concentrate in stoichiometric ratio conditions.
- NOx concentrate according to O2 purity (min. 90%),
process temperature and stoichiometric ratio regulation.

MATERIAL COMPOSITION:

- Metallic burner body: AISI310 / AISI316
- H2O cooling jacket (optional): AISI3016
- Burner refractory block (optional): Tmax 1800 °C
- Metallic body surface treatment: degreased
for O2 use



F3710HTI04

CAPACITY AND FLAME LENGTH PARAMETERS

The type of oxy-fuel flame generated by this series of burners is extremely compact thanks to the high mixture

degree yielded by the geometrical shape of the combustion head.

Model	Capacity kW	Flame length mm	Flame speed (m/s)	Ignition	Detection
HT-0	20	300 ÷ 400	30 ÷ 90 m/s	WAND	UV-2
HT-1	50	400 ÷ 500	30 ÷ 90 m/s	WAND	UV-2
HT-2	100	600 ÷ 800	30 ÷ 90 m/s	WAND/P86PBC-FR	UV-2
HT-3	150	800 ÷ 1000	30 ÷ 90 m/s	WAND/P86PBC-FR	UV-2
HT-4	250	1000 ÷ 1200	30 ÷ 90 m/s	WAND/P86PBC-FR	UV-2
HT-5	400	1200 ÷ 1600	30 ÷ 90 m/s	WAND/P86PBC-FR	UV-2
HT-6	600	1500 ÷ 1800	30 ÷ 90 m/s	WAND/P86PBC-FR	UV-2
HT-7	800	2000 ÷ 2500	30 ÷ 90 m/s	WAND/P86PBC-FR	UV-2
HT-8	1200	2500 ÷ 3000	30 ÷ 90 m/s	WAND/P86PBC-FR	UV-2
HT-9	1800	3000 ÷ 3500	30 ÷ 90 m/s	P86PBC-FR	UV-2
HT-10	2400	3500 ÷ 4000	30 ÷ 90 m/s	P86PBC-FR	UV-2
HT-11	3200	4 ÷ 5000	30 ÷ 90 m/s	P86PBC-FR	UV-2
HT-12	4000	5 ÷ 6000	30 ÷ 90 m/s	P86PBC-FR	UV-2
HT-13	5000	6 ÷ 7000	30 ÷ 90 m/s	P86PBC-FR	UV-2

DESCRIPTION

The complete development of the oxidation reactions and the consequent energy release takes place in a localized form, ensuring maximum flame temperatures, making this type of burner appropriate only for certain applications in high temperature processes (see "Applications" list).

The flame is generated outside of the metallic burner body, directly in the furnace combustion chamber or inside the refractory block where expected. This is done to avoid flame backfiring phenomena that premix burners could be prone to.

WARNINGS

- The ESA HT burner series are meant to be used for fixed installations. If mobile installations are necessary (for example extraction supports) these burners must be provided with appropriate safety devices to avoid the presence of uncontrolled flames in the atmosphere.
- Burner ignition must always be carried out from minimum power moving gradually to maximum, facilitating ignition and reducing outlet over pressure.
- For all low temperature applications (up to 750°C), burner ignition and the command of the fuel gas solenoid valves must be carried out using a certified burner control device.
- Check the correct connection for the feeding lines after installation. Before switching the burner on, check the correct oxygen and fuel gas pressures.
- The burner can work within a different power range compared with the specifications in this document, provided that this has been suggested by ESA - PYRONICS according to the application and the known exercise pressure. Functioning with excessive pressures could compromise the performance and life span of the actual burner, in which case, the general warrantee conditions will automatically expire and ESA-PYRONICS will not be held responsible for possible damage to persons or things.
- If problems should occur with other devices during the burner start-up phase, for the HT (high tension) cable connection to the electrode, use an anti disturbance filter.
- Avoid burner ignition close to each other so as not to heat the ignition command system devices (solenoid valves and transformers). Prepurge time lapse + first safety time lapse + min. of 5 sec. = time lapse between one ignition and another. (However, do not attempt more than 2 ignitions during a 30sec. time lapse).
- Make sure the power supply is TURNED OFF when intervening on the burner and its devices. In case of burner malfunctioning, follow the indications in the 'Maintenance' chapter of the present manual or contact ESA-PYRONICS assistance.
- Any modification or repair done by third parties may compromise the application safety and automatically cause the general warrantee conditions to expire..

INSTALLATION

The HT series burners are generally wall or roof installed burners. The metallic body of the burner has a coupling flange with a high temperature gasket, appropriate for direct furnace wall coupling or for the related refractory block. In the case of 'mobile' installations, the metallic body is provided with a coupling 'door' coated in ceramic fiber, solidly fixed to the burner, to limit the leaking of hot gases and flames through the hollow space between the burner and the furnace wall.

■ Burner equipped with only the metallic body for direct housing in the furnace wall.

The light made for the burner housing must have a free space around the burner that must then be filled with fiber ceramic cushion.

■ Burner equipped with H2O cooling jacket.

The light made for the burner housing must have a free space around the burner that must then be filled with fiber ceramic cushion (see dedicated data sheet).

■ Burner equipped with refractory block.

The light made for the burner housing must have a free space around the burner that must then be filled with fibre ceramic cushion (see dedicated data sheet).

The use of flexible hoses in AISI is compulsory for the oxygen and gas connection to the burner. The oxygen and gas inlets can be freely rotated at 90° and have flanges (UNI or ESA-PYRONICS) or be threaded according to the burner size.

For installation, carefully follow the instructions:

- 1 - place the burner body gasket onto the furnace wall.
- 2 - lift the burner and secure it to the stud bolts, making sure that the gasket hasn't moved or isn't deformed.
- 3 - tighten the fixing bolts.
- 4 - connect the oxygen and gas lines to the burner

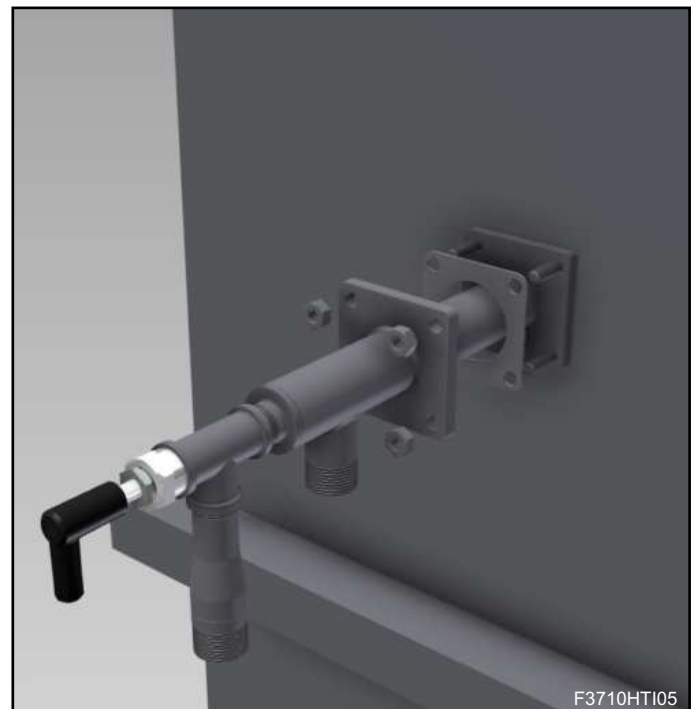

IGNITION AND SETTING

The operations indicated in the following chapter must be carried out by qualified technicians. The non-observance of the instructions given can provoke dangerous conditions.

1 - Check that the oxygen and fuel gas supply pressures are within the allowed or expected design range .

2 - Regulate the working pressures and the intervention of the combustion plant safety devices, whether there is one per burner or whether they are general plant safety devices such as: gas pressure reducer, block valve, vent valve, pressure switches etc. Simulate the intervention of all the safety devices, including the intervention of the high temperature safety device, checking that the fuel block devices act correctly.

3 - Activate the burner control device and attempt pilot burner ignition (*) until the actual burner ignites. During ignition attempts, act on the gas regulation valve, and, starting from the totally closed position, gradually open the valve until reaching main burner ignition.

4 - Repeat the ignition attempts at minimum burner power, moving onto the maximum power, to check the reliability and stability of the flame during regulation.

(*) for pilot burner ignition and setting, see data sheet E3280.

GENERAL MAINTENANCE PLAN

Operation	Type	Suggested time	Notes
Connector for high volt pilot burner electrode	O	annual	check the integrity of the outer plastic and oxidization of the internal connector and of the electrode terminal.
Pilot burner ignition electrode	O	annual	replace if the kantal terminal is worn.
Refractory block integrity	E	annual	at every maintenance check with furnace turned off, from the inside, make sure there are no cracks in the refractory material.
Cleaning of uv-scanner watch glass	O	every six months	reduce to every three months in dusty environments.
Uv-scanner replacement	O	10.000 h. of functioning	every 2 years.
Replacement of oxygen and gas gaskets (*)	E	annual	see note.
Burner setting	O	annual	repeat all the steps in the "IGNITION AND SETTING" section.

NOTES:

KEY: O = ordinary / E = extraordinary

(*) we suggest the you replace the gaskets after every time the gas and oxygen lines are dismantled and use high temperature gaskets.

ORDERING CODE - COMPLETE BURNER

HT - - - - -
01 02 03 04 05

Modello		01
HT-1	1	
HT-6	6	
HT-11	11	
...(see capacity table)	

04 Detection type	
Uv-scanner	UV
Electrode	E
No device	N

Fuel type		02
CH4	CH4	
Natural gas	LPG	
Poor gas	GP	

05 Accessories	
H2O jacket	H2O
Refractory block	BL
Metallic body	ND

Ignition type		03
Pilot	P	
Electrode	E	
No device	NI	