

Accessories



Simple measuring discs

POP-WAC (E5021 rev. 01 - 09/11/2012)

GENERAL WARNINGS:



■ All installation, maintenance, ignition and setting must be performed by qualified staff, respecting the norms present at the time and place of the installation.

■ To avoid damage to people and things, it is essential to observe all the points indicated in this handbook. The reported indications do not exonerate the Client/User from observing general or specific laws concerning accidents and environmental safeguarding.

■ The operator must wear proper DPI clothing (shoes, helmets...) and respect the general safety, prevention and precaution norms.

■ To avoid the risks of burns or high voltage electrocution, the operator must avoid all contact with the burner and its control devices during the ignition phase and while it is running at high temperatures.

■ All ordinary and extraordinary maintenance must be performed when the system is stopped.

■ To assure correct and safe use of the combustion plant, it is of extreme importance that the contents of this document be brought to the attention of and be meticulously observed by all personnel in charge of controlling and working the devices.

■ The functioning of a combustion plant can be dangerous and cause injuries to persons or damage to equipment. Every burner must be provided with certified combustion safety and supervision devices.

■ The burner must be installed correctly to prevent any type of accidental/undesired heat transmission from the flame to the operator or the equipment.

■ The performances indicated in this technical document regarding the range of products are a result of experimental tests carried out at ESA-PYRONICS. The tests have been performed using ignition systems, flame detectors and supervisors developed by ESA-PYRONICS. The respect of the above mentioned functioning conditions cannot be guaranteed if equipment, which is not present in the ESA-PYRONICS catalogue, is used.

DISPOSAL:



To dispose of the product, abide by the local legislations regarding it.

GENERAL NOTES:



■ In accordance to the internal policy of constant quality improvement, ESA-PYRONICS reserves the right to modify the technical characteristics of the present document at any time and without warning.

■ It is possible to download technical sheets which have been updated to the latest revision from the **www.esa-pyronics.com** website.

■ The products manufactured by ESA-PYRONICS have been created in conformity to the **UNI EN 746-2:2010** Norms: Equipment for industrial thermal process - Part 2: Safety requirements for combustion and the movement and treatment of combustible elements. This norm is in harmony with the Machine Directive **2006/42/CE**. It is certified that the products in question respect all the requirements prescribed by the above mentioned Norms and Directives.

■ Certified in conformity with the **UNI EN ISO 9001** Norm by DNV GL.

CERTIFICATIONS:



EN5167-2 Fluid measurement via EN differential pressure devices placed inside full circular pipe sections - Part 2: Diaphragms

EN331 Ball valves and male cone-shaped valves with closed ends, manually controlled valves, for gas systems in buildings.



The products conform to the requests for the Euroasia market (Russia, Belarus and Kazakhstan).

CONTACTS / SERVICE:



Headquarters:

Esa S.p.A.
Via Enrico Fermi 40
24035 Curno (BG) - Italy
Tel +39.035.6227411
Fax +39.035.6227499
esa@esacombustion.it

International Sales:

Pyronics International s.a.
Zoning Industriel, 4ème rue
B-6040 Jumet - Belgium
Tel +32.71.256970
Fax +32.71.256979
marketing@pyronics.be

www.esapyronics.com

The POP-WAC series discs are simple measuring orifices according to the UNI EN5167-2 Norm. they are available in various types of material and sizes according to the type of fluid and flow that they must measure.

APPLICATIONS

- Flow measurement.
- Flow ratio coupled with pressure transmitters.
- Flow direction control coupled with pressure switches.
- Control of combustion chamber pre purge or of burner ignition at minimum power (according to the EN746/2 Norm).

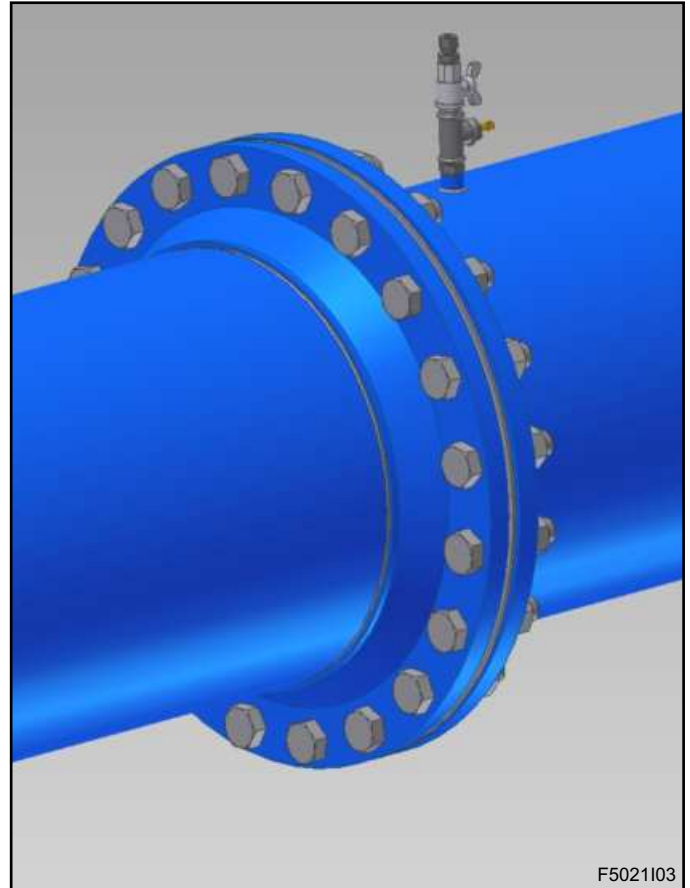

F5021103

CHARACTERISTICS

Primary measuring element:

- | | |
|------------------------------|-----------------|
| ■ Disc: | AISI304 / OT58 |
| ■ Maximum working pressure: | 5 bar |
| ■ Maximum fluid temperature: | 500°C |
| ■ UNI PN16 flange: | Fe360 / AISI304 |
| ■ Gaskets: | AFM-34 / X-PLUS |
| ■ Regulations: | UNI EN5167.2 |

Impulse line socket kit (not included):

- | | |
|---|-----------------------------|
| ■ Pressure tap: | OT58 |
| ■ Fittings: | nickel-plated brass/AISI321 |
| ■ Connecting pipes (not supplied, by customer): | brass |



F5021104

DESCRIPTION

The POP-WAC series discs are simple measuring orifices manufactured according to the UNI EN5167-2 Norm to measure fluid flow via differential pressure devices placed inside ducts with full circular sections. The measuring principle is based on the installation of a calibrated orifice inside the pipe.

The presence of this orifice causes a static pressure difference between the upstream part and the downstream part of the orifice. Measuring takes place by a secondary element, generally it is a differential pressure gauge or pressure transmitter.

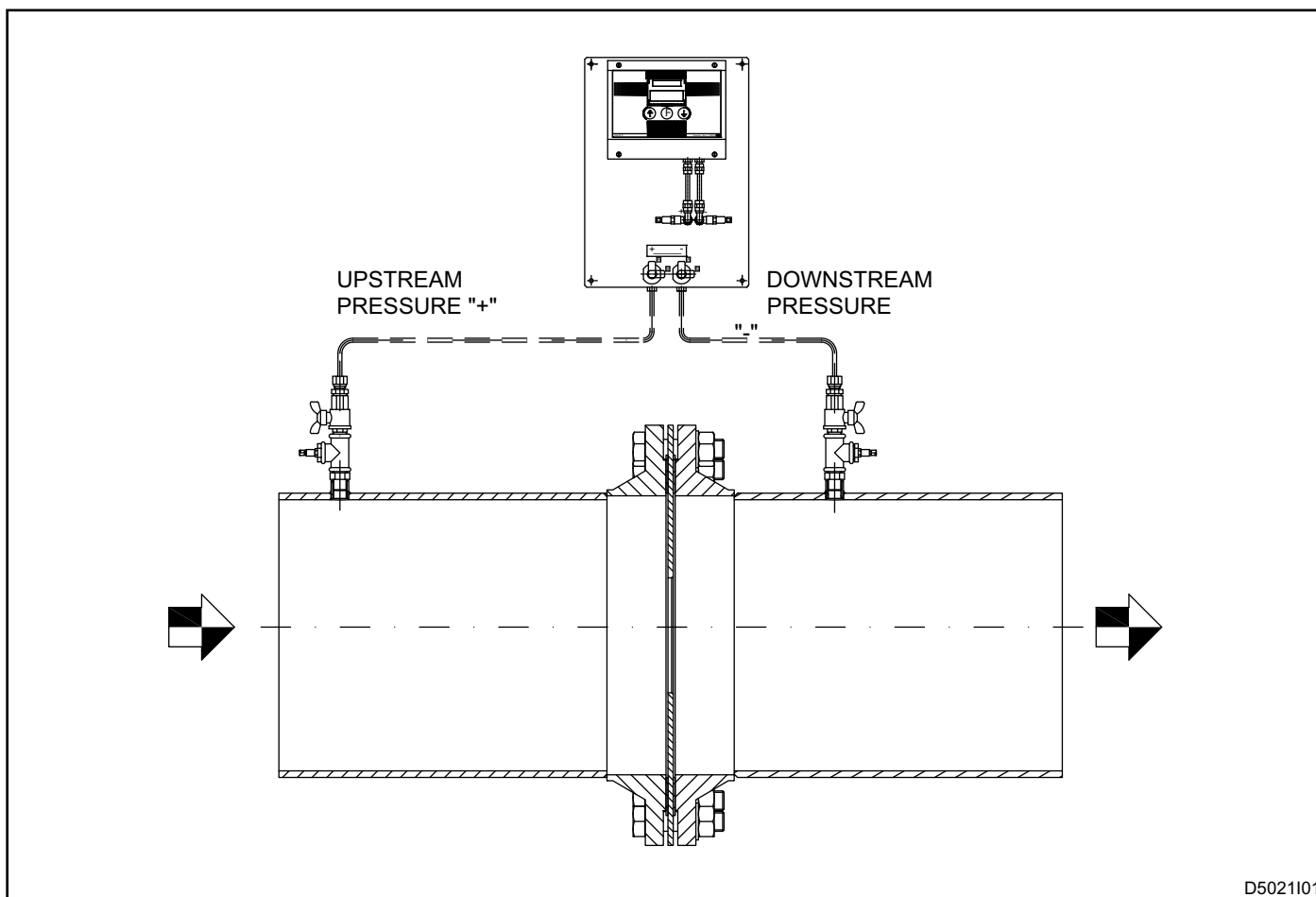

D5021101

INFORMATION FOR SIZING

To be able to correctly size the orifice hole inside the POP-WAC series calibrated flanges, the following project data available must be available:

- Fluid type
- Nominal pipe flow
- Differential pressure on calibrated flange
- Working pressure and temperature
- Nominal diameter of pipe (DN)
- Internal diameter of pipe (if not standard)

IMPULSE LINE SOCKET KIT (NOT INCLUDED)

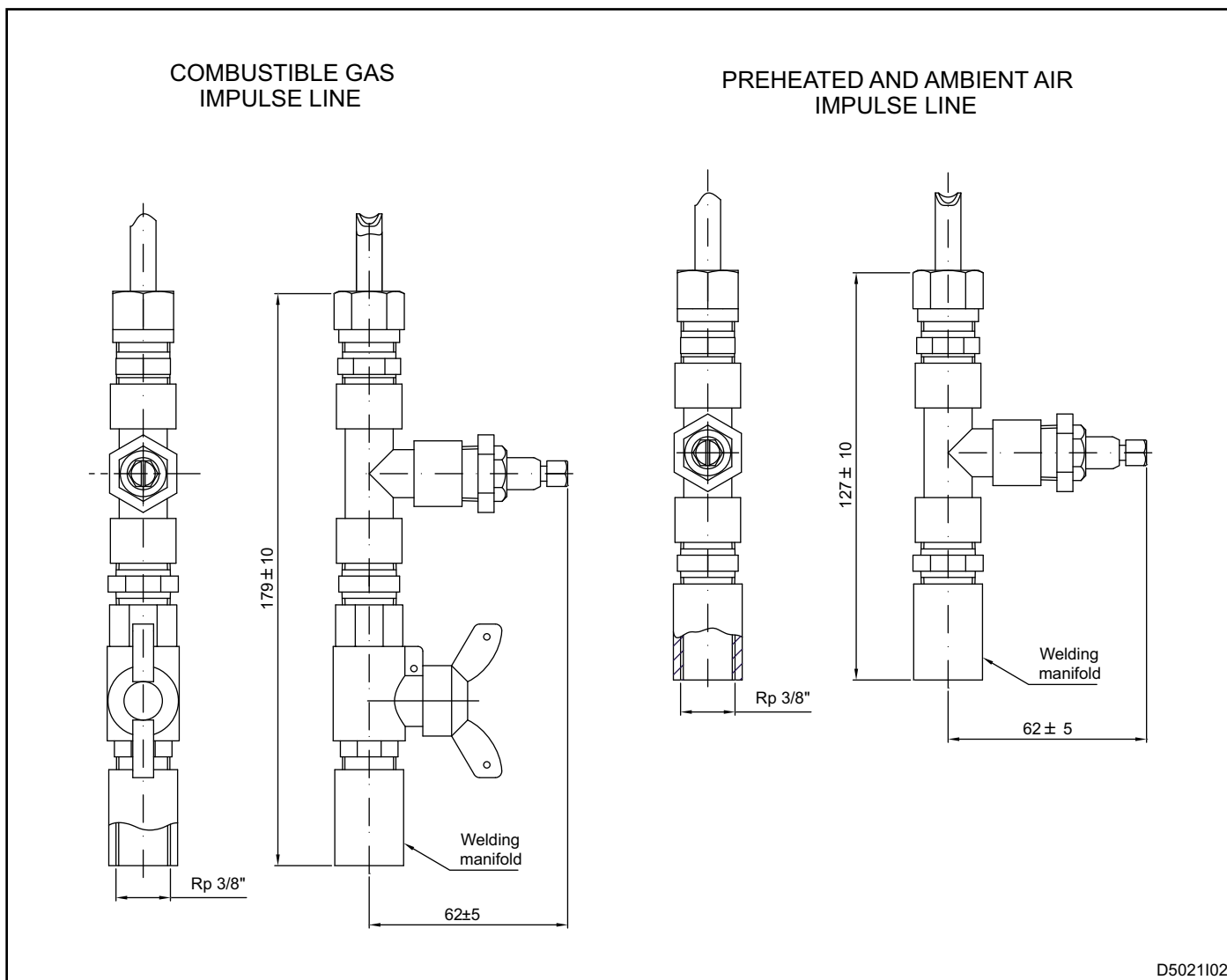

D5021102

The calibrated flanges of the POP-WAC series are supplied on request with special impulse line socket kits, for which the installation must be done by the customer. This kit allows to connect the flange to the appropriate pressure transmitters that read the differential pressure between

upstream and downstream the orifice. They give a precise indication of the fluid flow inside the pipe (according to the UNI EN5167-2 Norm). The kits can be supplied according to the fluid inside the pipes.

PIPE VOLUMETRIC FLOW CHART

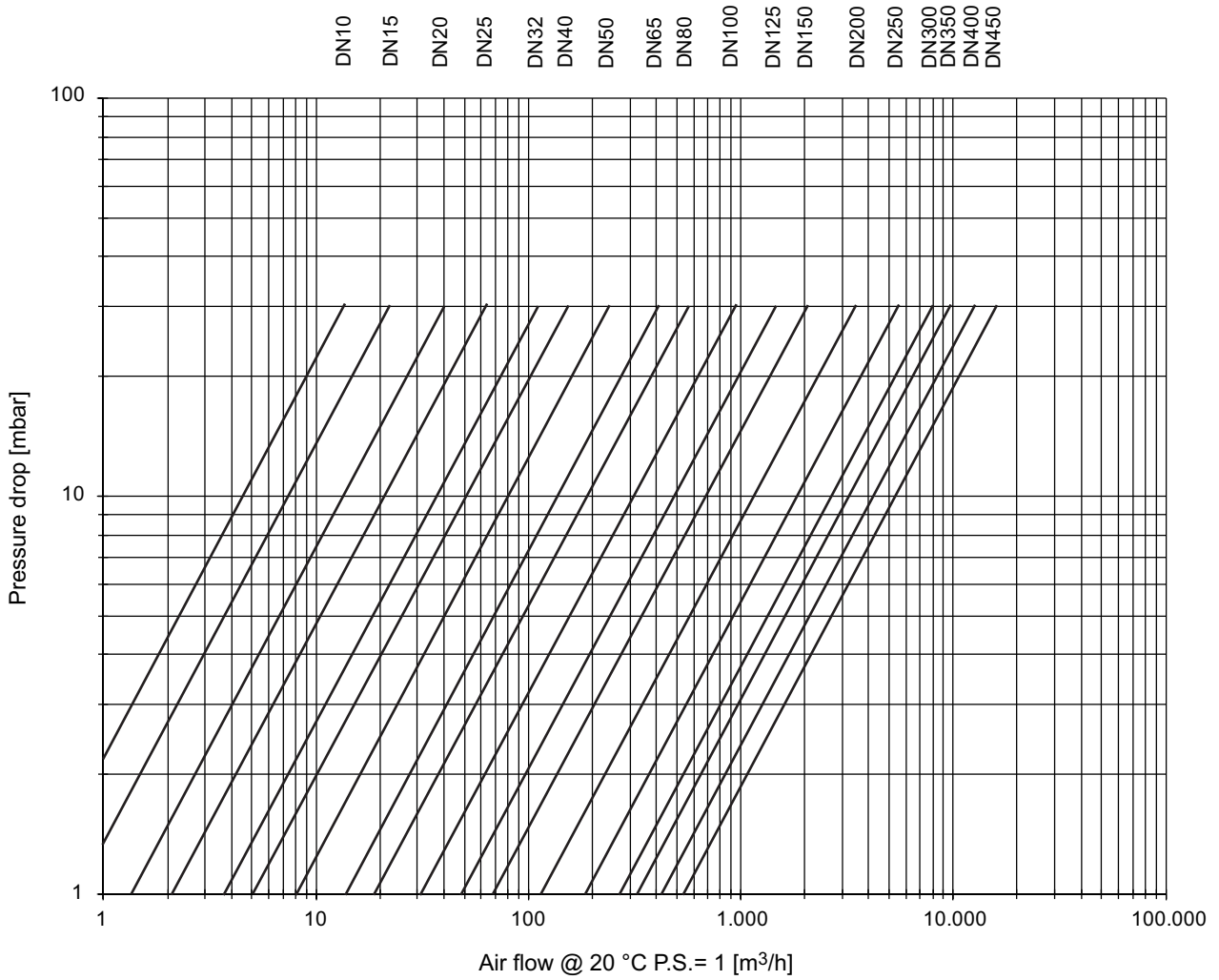

MINIMUM LENGTH OF THE STRAIGHT PIPES UPSTREAM AND DOWNSTREAM OF THE PRIMARY ELEMENT:

Diameter ratio β	Minimum length upstream the primary element*						Minimum length downstream*	
	Simple 90° curve or T piece (flow in only one branch)	Two or more 90° coplanar curves	Two or more 90° curves on different planes	Widening from 0,5D to D on a length of D to 2D	Reduction from 2D to D on a length of 1,5D to 3,5D	Valve with completely open shutter	Shutter completely open	For any situation
≤ 0.20	10 (6)	14 (7)	34 (17)	16 (8)	5	18 (9)	12 (6)	4 (2)
0.25	10 (6)	14 (7)	34 (17)	16 (8)	5	18 (9)	12 (6)	4 (2)
0.30	10 (6)	16 (8)	34 (17)	16 (8)	5	18 (9)	12 (6)	5 (2,5)
0.35	12 (6)	16 (8)	36 (18)	16 (8)	5	18 (9)	12 (6)	5 (2,5)
0.40	14 (7)	18 (9)	36 (18)	16 (8)	5	20 (10)	12 (6)	6 (3)
0.45	14 (7)	18 (9)	38 (19)	17 (9)	5	20 (10)	12 (6)	6 (3)
0.50	14 (7)	20 (10)	40 (20)	18 (9)	6 (5)	22 (11)	12 (6)	6 (3)
0.55	16 (8)	22 (11)	44 (22)	20 (10)	8 (5)	24 (12)	14 (7)	6 (3)
0.60	18 (9)	26 (13)	48 (24)	22 (11)	9 (5)	26 (13)	14 (7)	7 (3,5)
0.65	22 (11)	32 (16)	54 (27)	25 (13)	11 (6)	28 (14)	16 (8)	7 (3,5)
0.70	28 (14)	36 (18)	62 (31)	30 (15)	14 (7)	32 (16)	20 (10)	7 (3,5)
0.75	36 (18)	42 (21)	70 (35)	38 (19)	22 (11)	36 (18)	24 (12)	8 (4)
0.80	46 (23)	50 (25)	80 (40)	54 (27)	30 (15)	44 (22)	30 (15)	8 (4)
For all values β	Special pieces				Minimum length upstream*			
	Sharp diameter reduction ($D_1/D_2 \geq 0,5$)				30 (15)			
	Thermometric location diameter $\leq 0,03D$ $0,03D \leq \text{diameter} \leq 0,13D$				5 (3) 20 (10)			

* The values without parentheses are for a probable additional null error; the values in parentheses are for a probable additional error of +/- 0,5%. The lengths must be measured starting from the face upstream and downstream the primary element and are expressed in multiples of the diameter D. Weld two G3/8" sleeves on the pipe according to the distance L1 and L2 on page 3/8 facing upwards. Do not install socket probes facing downwards to avoid possible obstructions of the fittings that could

distort the readings. The choice of flange must be made also according to the fluid velocity in the pipe, which should be less than 20 m/s (see pipe volumetric flow chart). During the order phase, after having received all the necessary information (see note at the end of data sheet), ESA will calculate the orifice and check the flange applicability. Together with the calibrated flange the ΔP flow table is supplied as well as the orifice calculus.

FLOW SWITCH (NOT INCLUDED)

The new 2010 version of the EN746/2 Norm updated the part regarding the inspection to be carried out for the purging of the combustion chamber during furnace start-up and burner ignition with nominal power higher than 120kW, that must necessarily take place below 33% of the power. Following this update, it isn't sufficient to use a low air pressure switch on the pipe that ensures the correct blower ignition, but a differential pressure switch must be used (which in this case, becomes a minimum air flow switch) that can read the Δp of a calibrated flange and that gives permission to activate chamber purge as soon as the measured air flow exceeds 80% of the maximum nominal flow of the plant.

In the same way, it is not possible to switch the burners on at minimum capacity relying on the servo motor limit switches, but a differential pressure switch is used (which in this case becomes a maximum air flow switch) that allows burner ignition below 33% of the nominal power of each. For the above mentioned applications, we suggest the use of a calibrated POP-WAC flange correctly connected to a pair of differential pressure switches according to the scheme in the figure. For this, a special pressure switch mounting kit may be supplied.

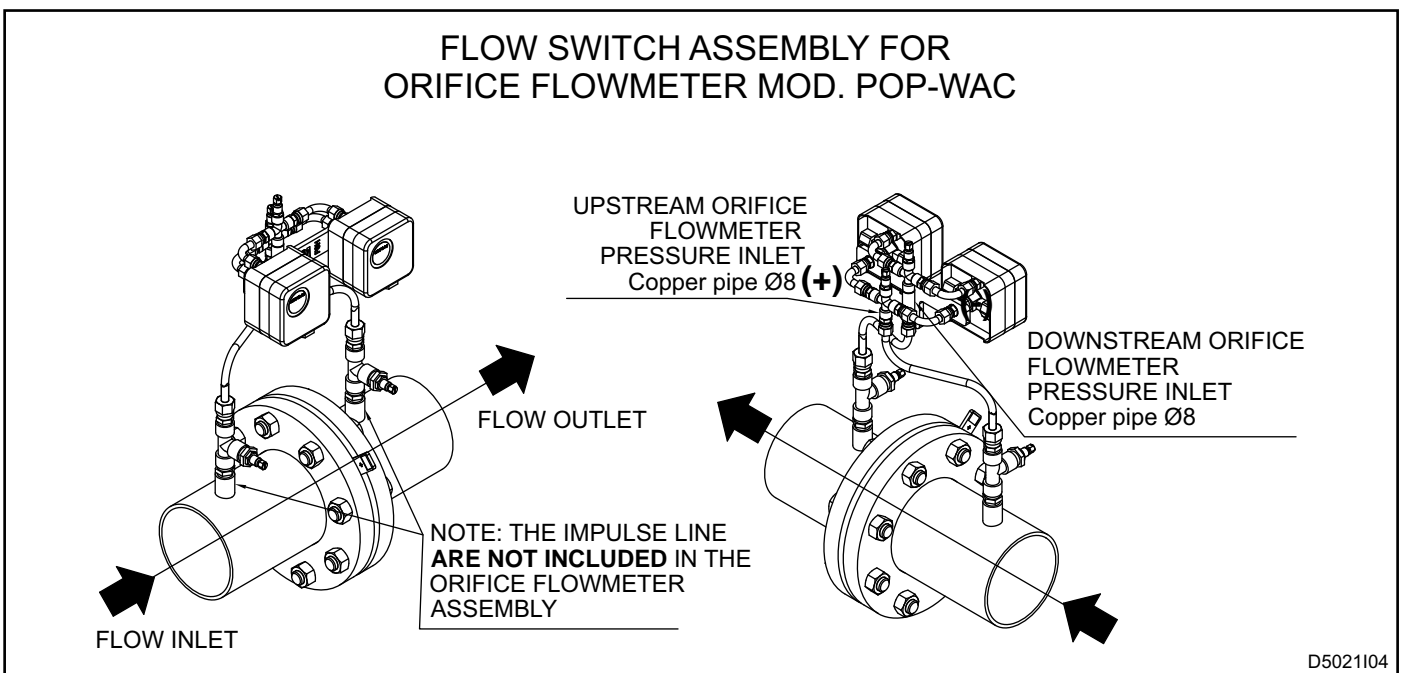
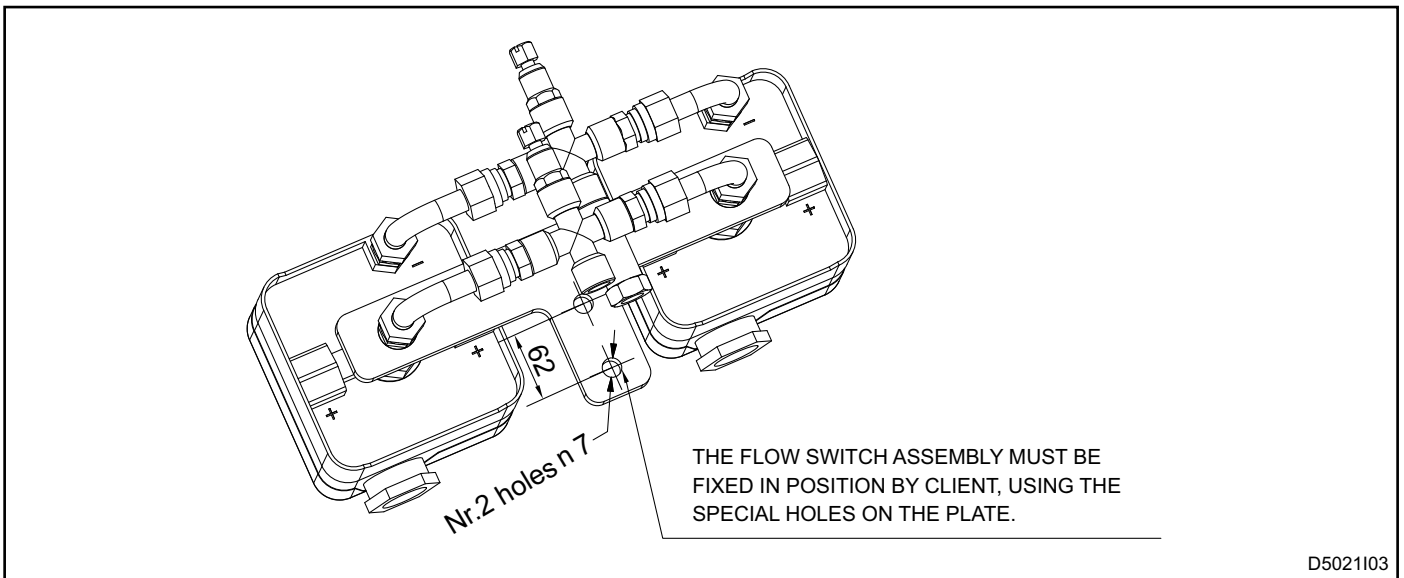

WARNINGS

- Make sure that the fluid working pressure and temperature are below the maximum allowed limits.
- The POP-WAC orifices are supplied without coupling flanges or gaskets. The flanges and gaskets to be applied must be fit for the type of valve and application.
- Check the correct installation of the POP-WAC orifice.
- Respect the diameters upstream and downstream the diameter ratio.
- Any change or repair done by third parties may compromise the application safety and cause the general warrantee conditions to automatically expire.

INSTALLATION

Maintenance and installation must be carried out by qualified staff, respecting the laws in force. After installation it is always advisable to carry out a tightness check on the threads or of the flange connections.

- 1 - For the mounting of the POP-WAC calibrated flange, follow the instructions printed on the actual flange.
- 2 - Check the correct alignment of the attachment pipes and maintain enough distance from the walls allowing air to circulate freely.
- 3 - Respect the upstream and downstream diameters according to the table.
- 4 - Make sure that no foreign bodies enter the valve body before assembling, if necessary blow with compressed air.
- 5 - Weld the flanges onto the ends of the pipes, eliminating any welding burrs.
- 6 - Place the gaskets (chosen according to the type of fluid) and insert the bolts.
- 7 - Place the orifice in the right direction. The printed symbol "+" must be placed upstream on the pipe with the orifice hole's 45° chamfer facing downstream the pipe.
- 8 - Using appropriate tools, progressively tighten cross-wise.
- 9 - Avoid excessive tightening and mount without voltage.
- 10 - Weld two G3/8" sleeves on the pipe according to the distance L1 and L2 supplied on page 11, facing upwards. Do not install socket probes facing downwards to avoid possible obstruction of the fittings that could distort the readings.

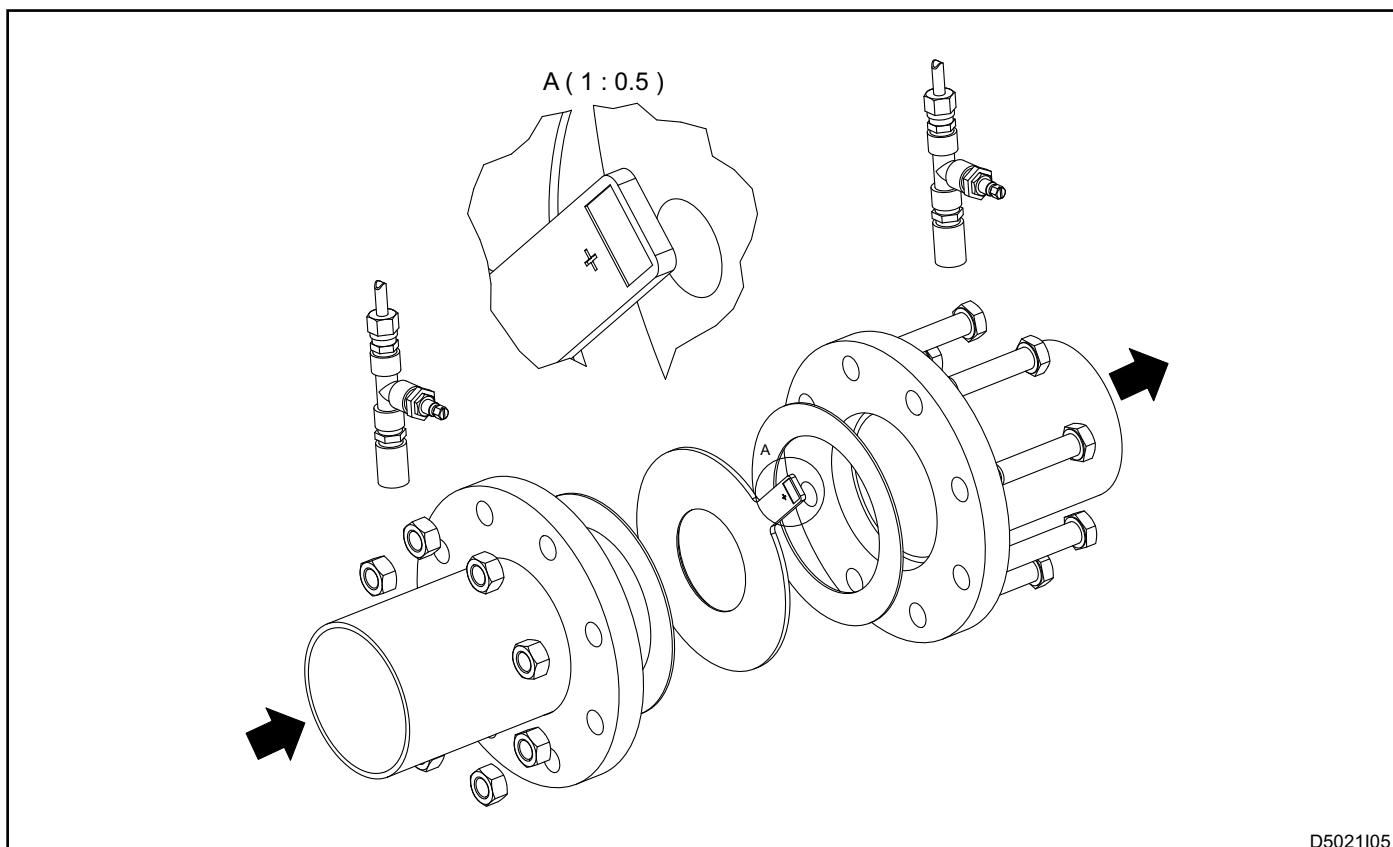

D5021I05

GENERAL MAINTENANCE PLAN

Operation	Type	Advised timing	Notes
Gasket integrity	O	annual	Check that there are no leaks on the outside
Impulse socket integrity	O	annual	Check that there are no leaks on the outside

O = Ordinary

ORDINARY MAINTENANCE

For correct maintenance of the POP-WAC organs, scrupulously follow the these instructions. Before carrying out manouvres with the plant on, make sure that the process safety and operator safety are not comprised. If necessary carry out inspection with plant off.

INTEGRITY CHECK

The integrity of the gaskets and threads can be checked visually. If necessary, use liquid leak detector.

EXTRAORDINARY MAINTENANCE

For correct maintenance of the POP-WAC orifices, scrupulously follow the instructions below that must be carried out with the plant off.

BOLT TIGHTNENING

1 - The tightness must be checked with the plant off.

GASKET REPLACEMENT

2 - Progressively unscrew the screws that hold the valve crosswise. Extract the orifice and replace the gasket.

3 - Clean the inside of the orifice with a clean cloth and compressed air. Do not use tools that could damage the internal parts.

OVERALL DIMENSIONS

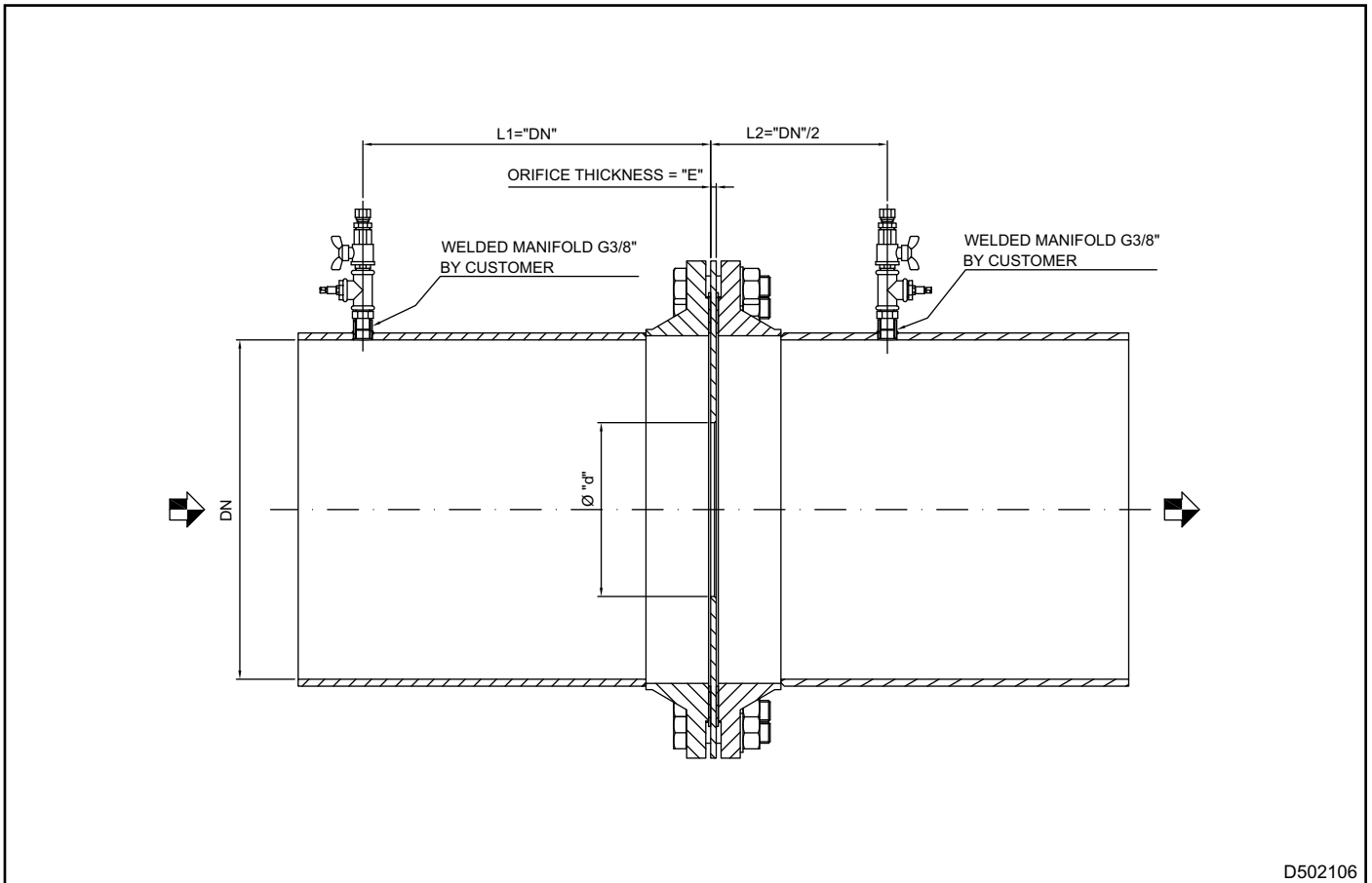

D502106

Model	DN	dmin	dmax	L1 max	L1 min	L2 max	L2 min	E
48POP-WAC	150	15	112.5	165	135	78	72	4
64POP-WAC	200	20	150	220	180	104	96	4
80POP-WAC	250	25	187.5	275	225	130	120	4
96POP-WAC	300	30	225	330	270	156	144	6
112POP-WAC	350	35	262.5	385	315	182	168	6
128POP-WAC	400	40	300	440	360	208	192	6
144POP-WAC	450	45	337.5	495	405	234	216	8
160POP-WAC	500	50	375	550	450	260	240	8
192POP-WAC	600	60	450	660	540	312	288	8
224POP-WAC	700	70	525	770	630	364	336	10
256POP-WAC	800	80	600	880	720	416	384	10
288POP-WAC	900	90	675	990	810	468	432	12
320POP-WAC	1000	100	750	1100	900	520	480	12

Welding flanges according to UNI2282-67 PN16
L1 & L2 measured from the face upstream the orifice

ORDERING CODE - CALIBRATED ORIFICE ONLY

- POP - WAC -
01 02

MODEL		01
48	45	
64	64	
96	96	
112	112	
128	128	
144	144	
160	160	
....	...	
see table on page 11		

02	FLUID	
	Air	A
	Gas	G
	Oxygen	O
	Special gas	SG

Including:

- Calibrated orifice
- Welding flanges according to EN1092-1

Not included:

- Impulse kit for pressure transmitter or differential pressure gauge. The materials will be suitable for the type of fluid used in the pipes.
- Flow switches

ORDERING CODE - CALIBRATED ORIFICE ONLY

- OP - WAC -
01 02

MODEL		01
48	45	
64	64	
96	96	
112	112	
128	128	
144	144	
160	160	
....	...	
see table on page 11		

02	FLUID	
	Air	A
	Gas	G
	Oxygen	O
	Special gas	SG